

Assembly Steps:

4 TIERS HEAVY DUTY WIRE SHELVING WCS-S002 & WCS-S003

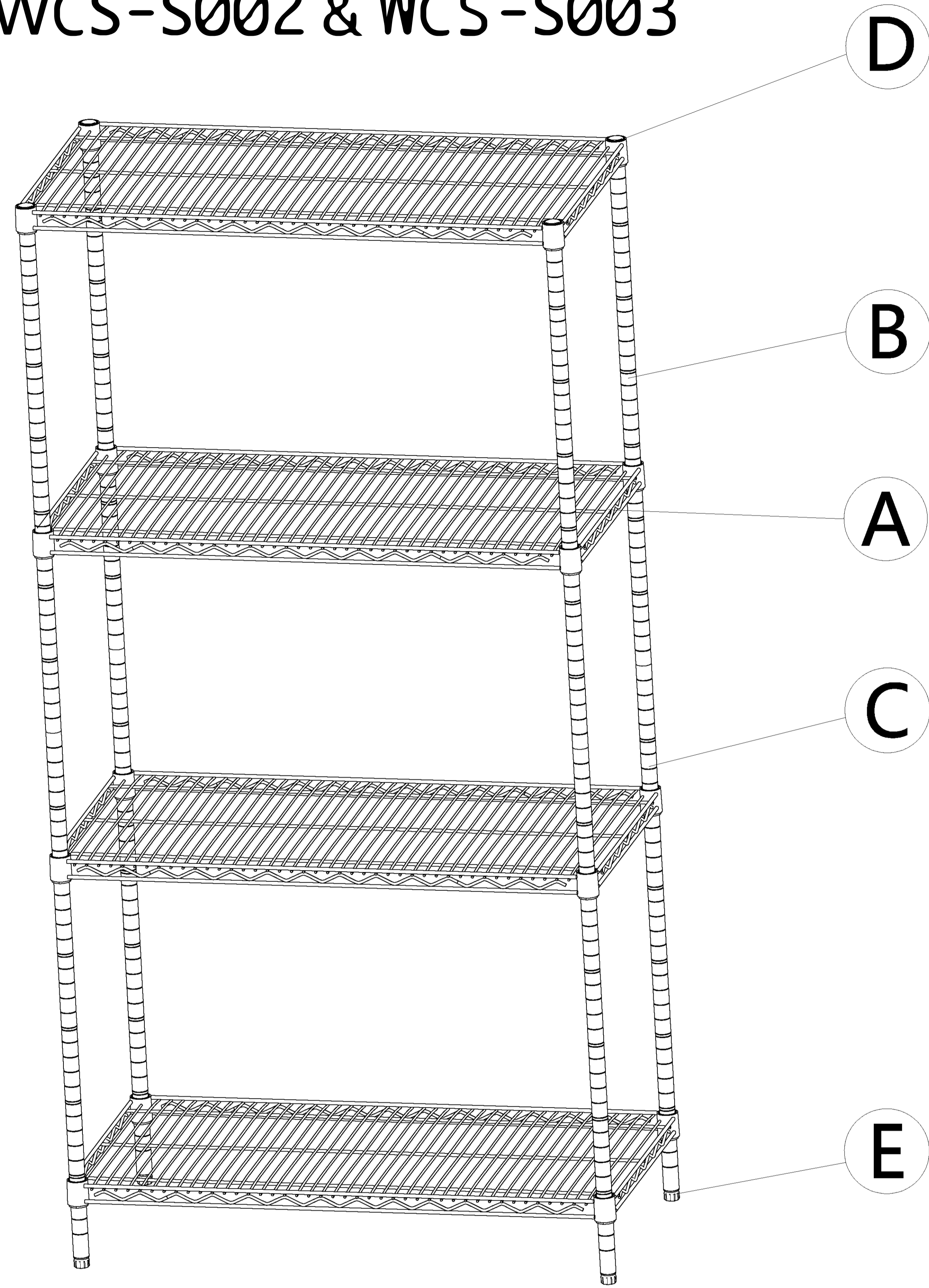

1 The Leveling Feet (E) had assembled into the bottom of four Lower Poles (C). Then snap the Plastic Clips (D) into the grooves of four lower poles at your desired position. Make sure the arrow of plastic clips are pointed up.

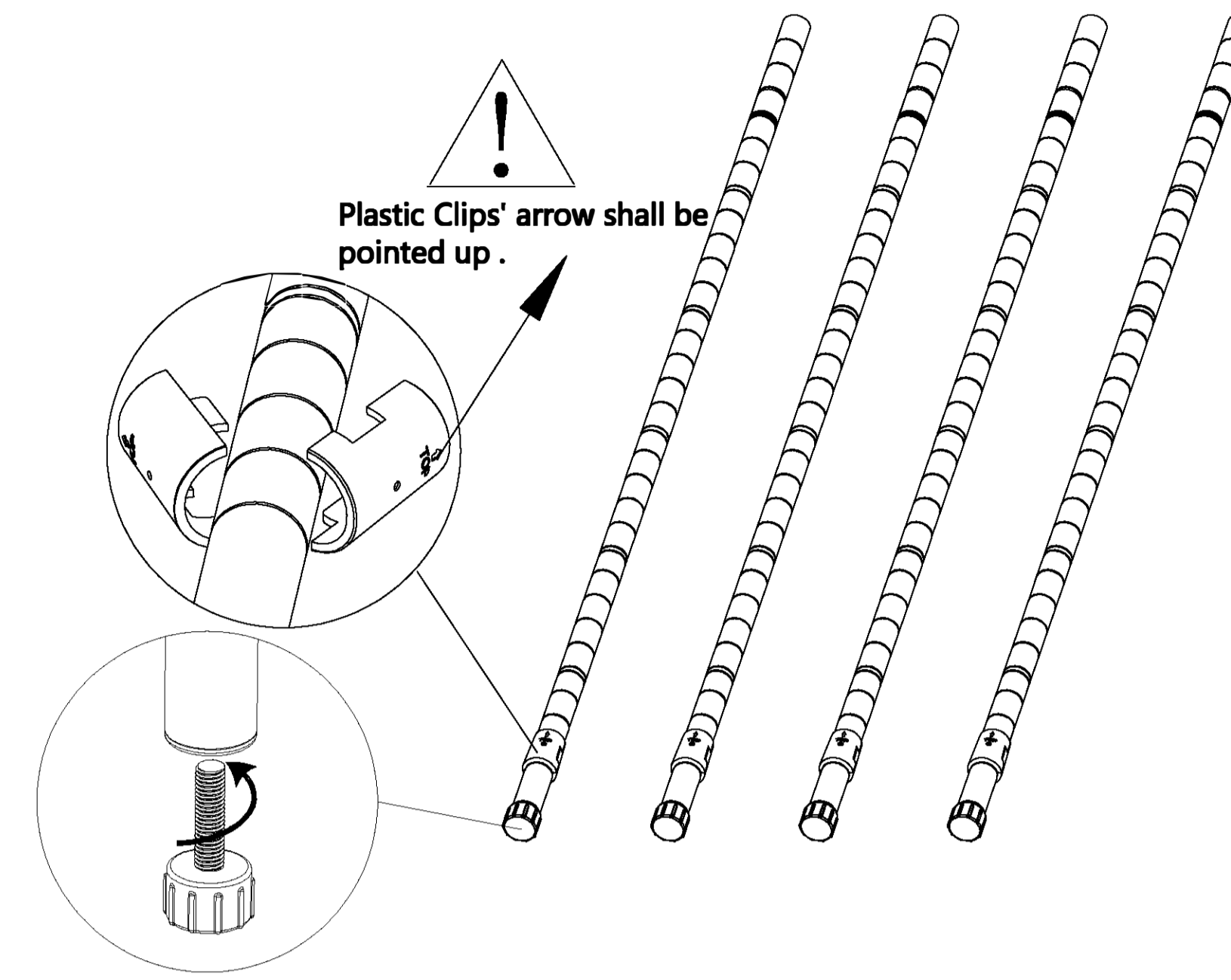

2 Please make sure that you have the Wire Shelf(A)the correct way up, hold the wire shelf on it's side and slide the top of four poles through the bottom of the wire shelf at it's corners until there is a snug fit,and then set the wire shelf upright.

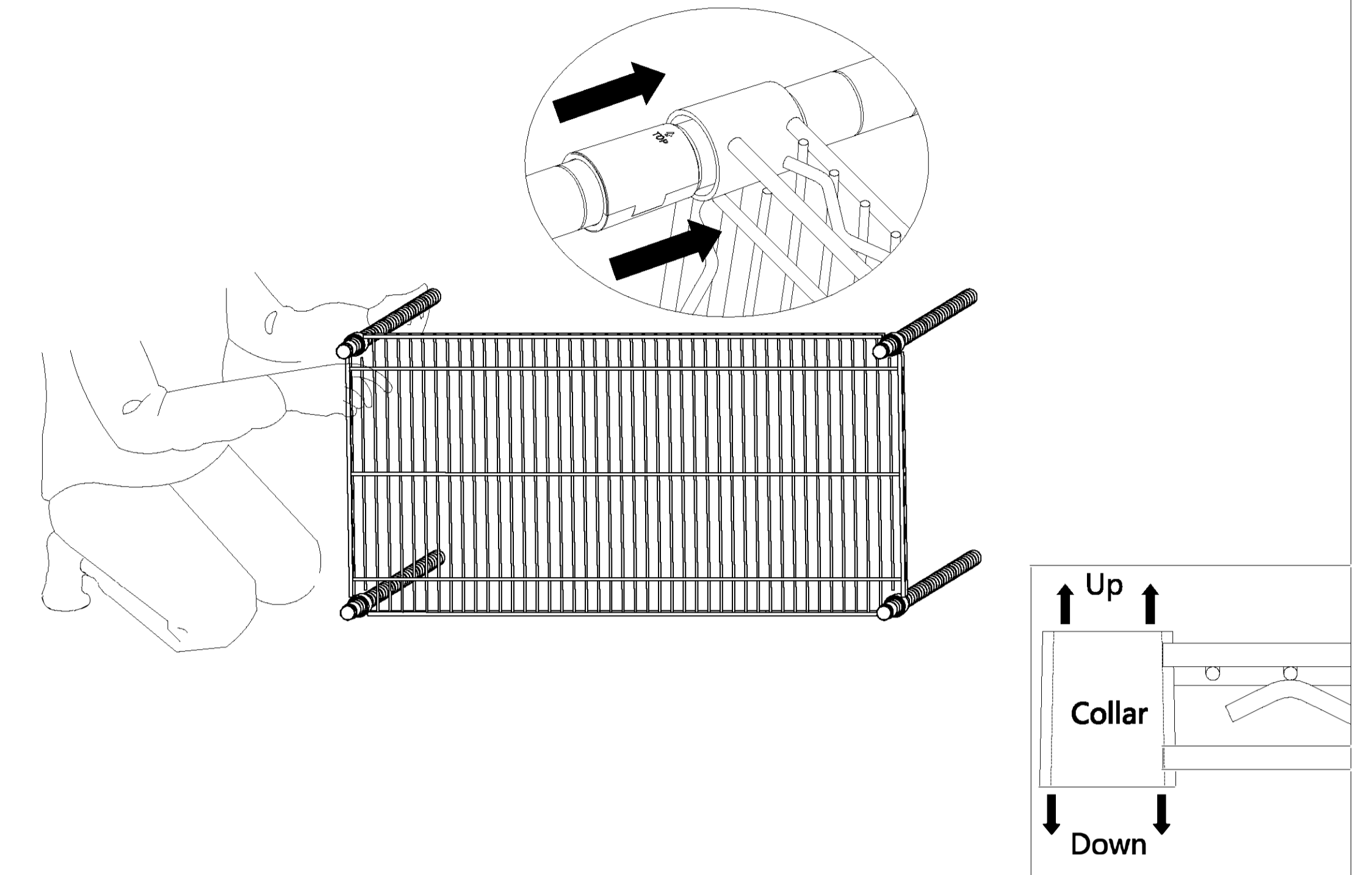

3 Snap plastic clips into the pole grooves at your desired position for next wire shelf. Slide down the shelf from top down onto the plastic clips .

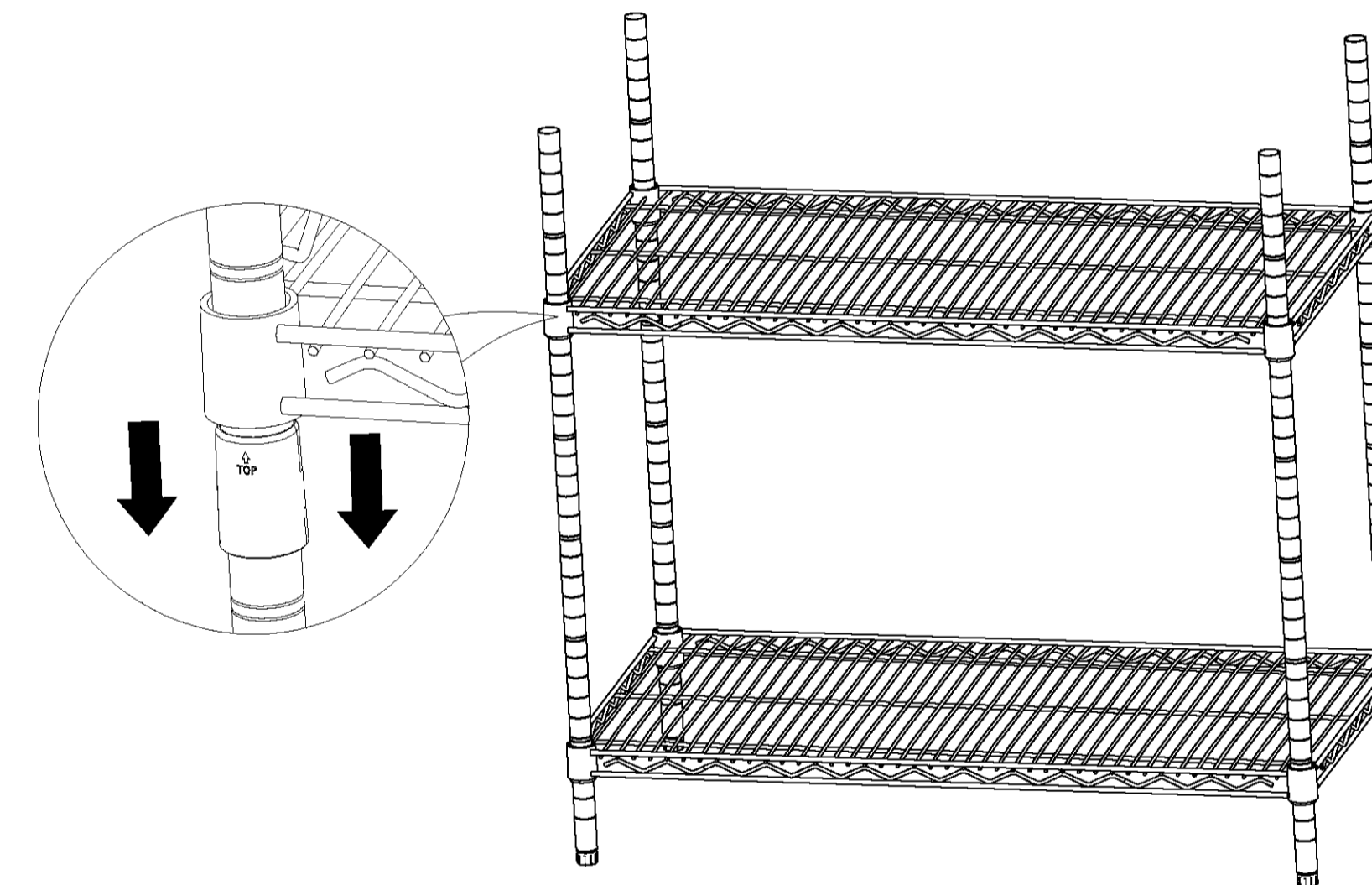

4 Screw Upper Poles (B) into lower poles by screw connectors which is already assembled on the upper poles.

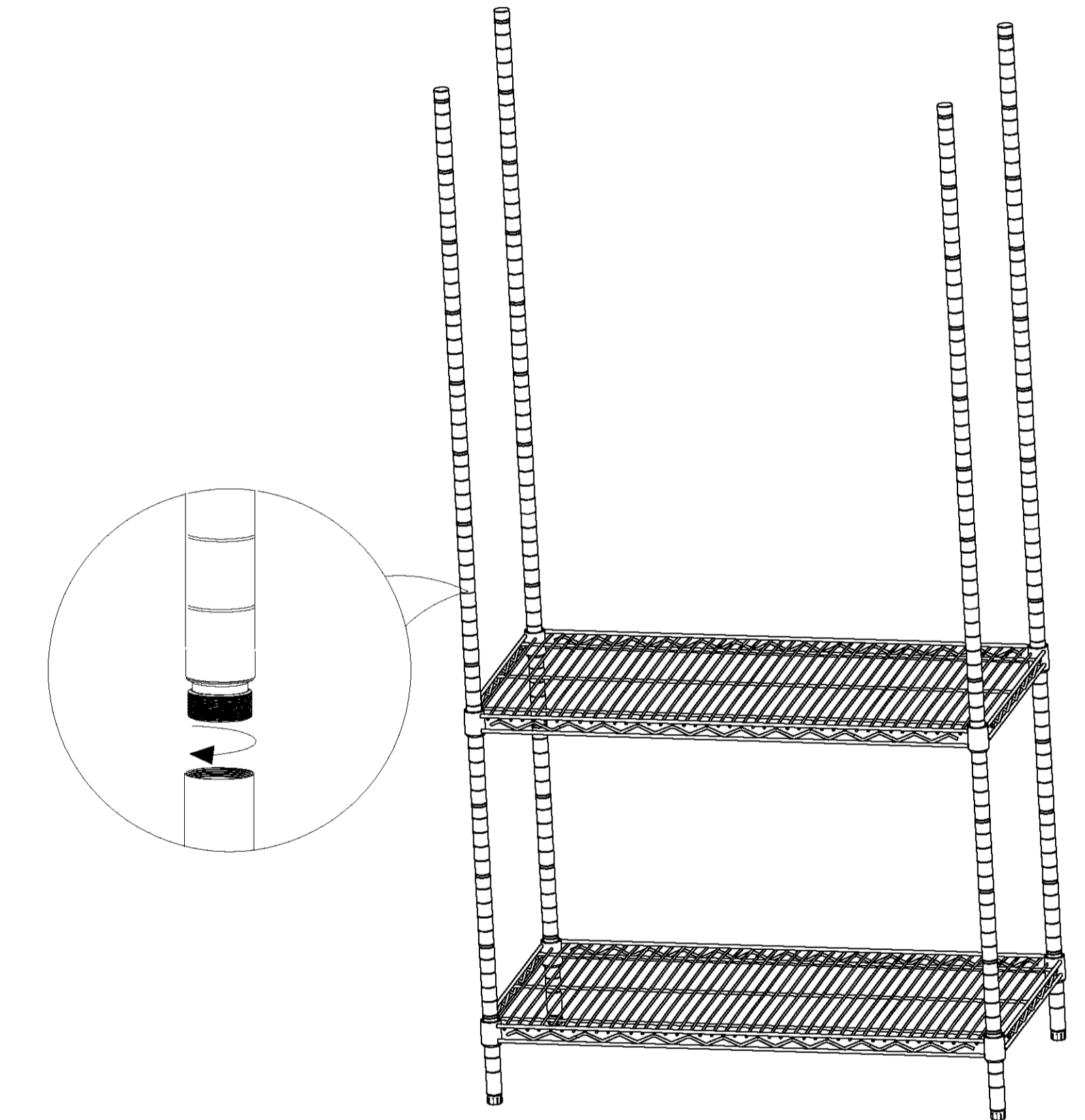

5 Repeat The Step 3 and assemble the rest of wire shelves.

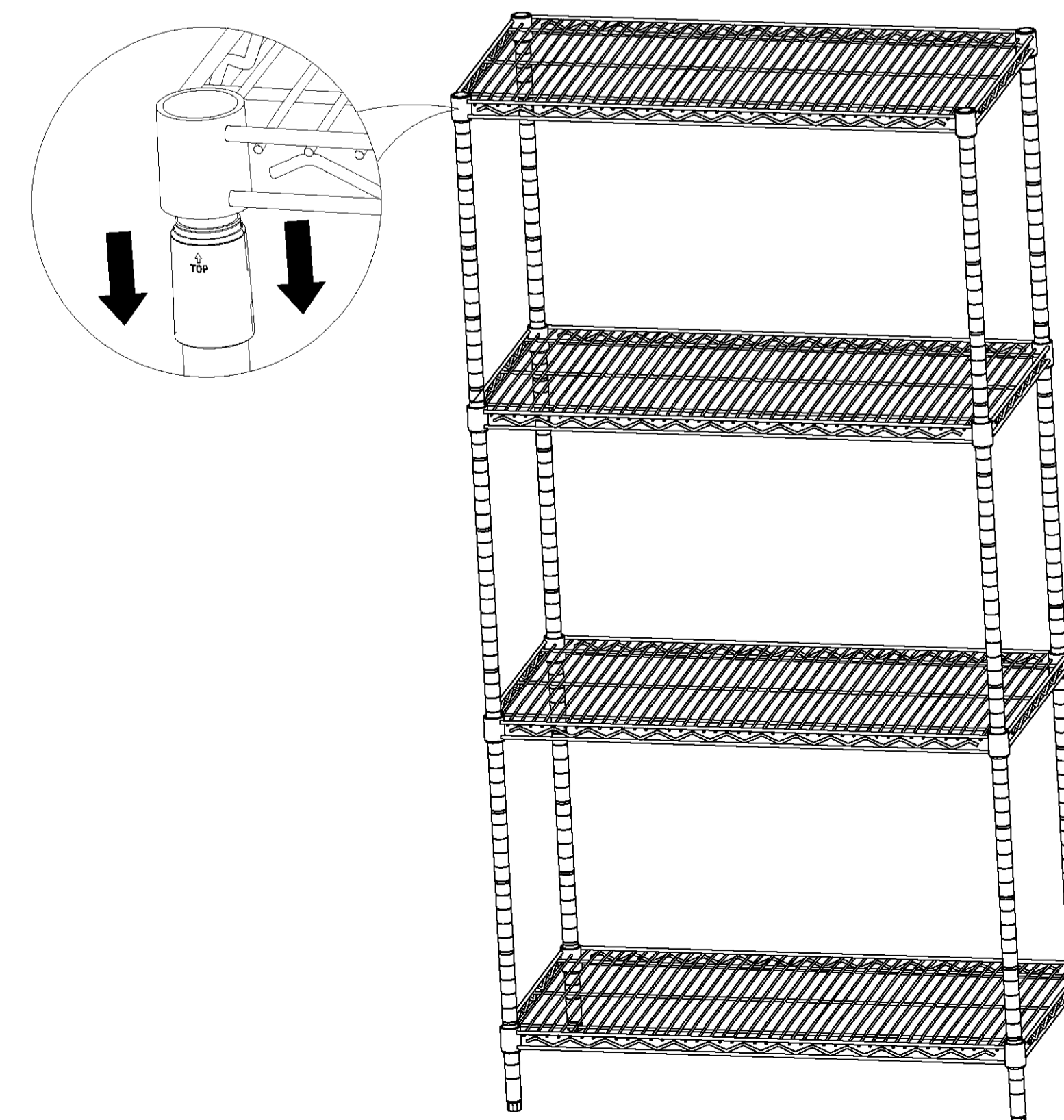

6 Once all the wire shelves have been installed, pushing firmly down on every shelf at corners by rubber mallet to ensure that the shelf in a place over the plastic clips. And screw the leveling feet in or out to attain proper leveling.

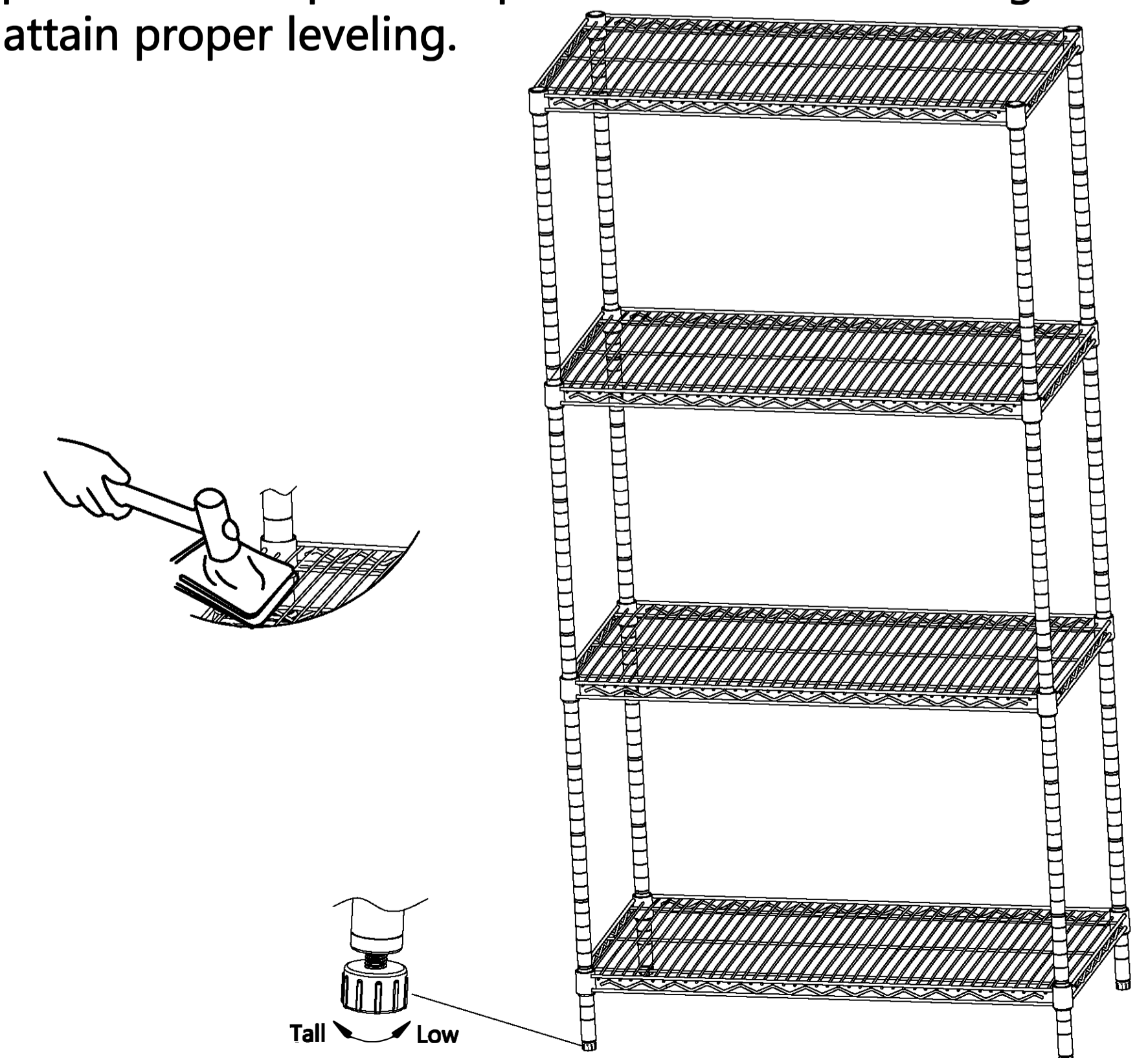

No.	A	B	C	D	E
Name	Wire Shelf	Upper Pole	Lower Pole	Plastic Clip	Leveling Foot
Parts					
Quantity	4PCS	4PCS	4PCS	32PCS	4PCS