

### Assembly Steps:

## 3 Tiers Working Table Rack WCS-T006

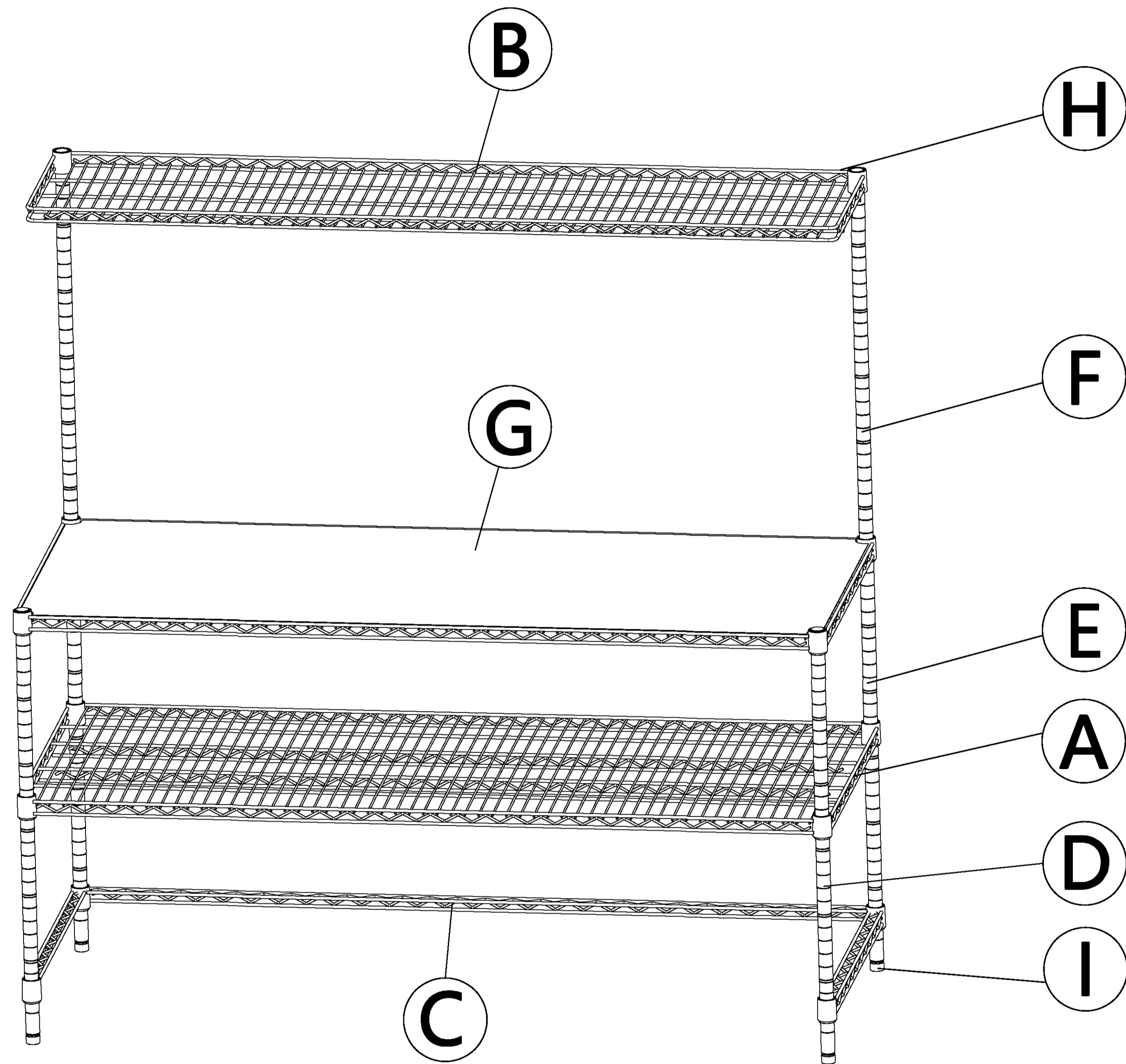

① Screw the leveling feet(I) into the bottom of front pole(D) and Lower poles(E).Snap plastic clips (H) onto the pole grooves of each pole at the same position and make sure that the arrow of plastic clips are pointing up.

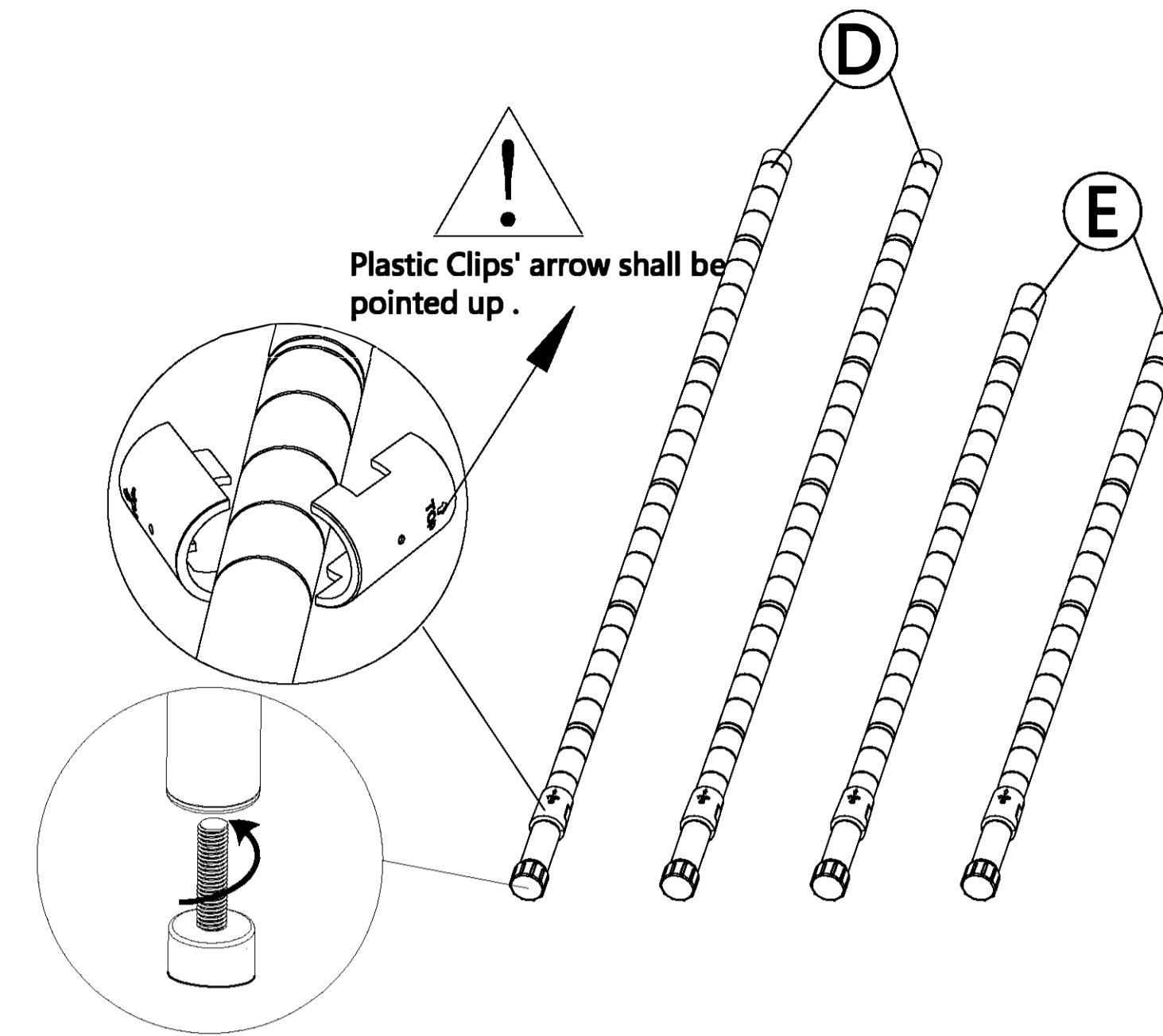

② Please make sure that you have the shelf frame(C) the correct way up,hold the shelf frame(C) on it's side and slide the top of four poles through the bottom of the wire shelf at it's corners until there is a snug fit.

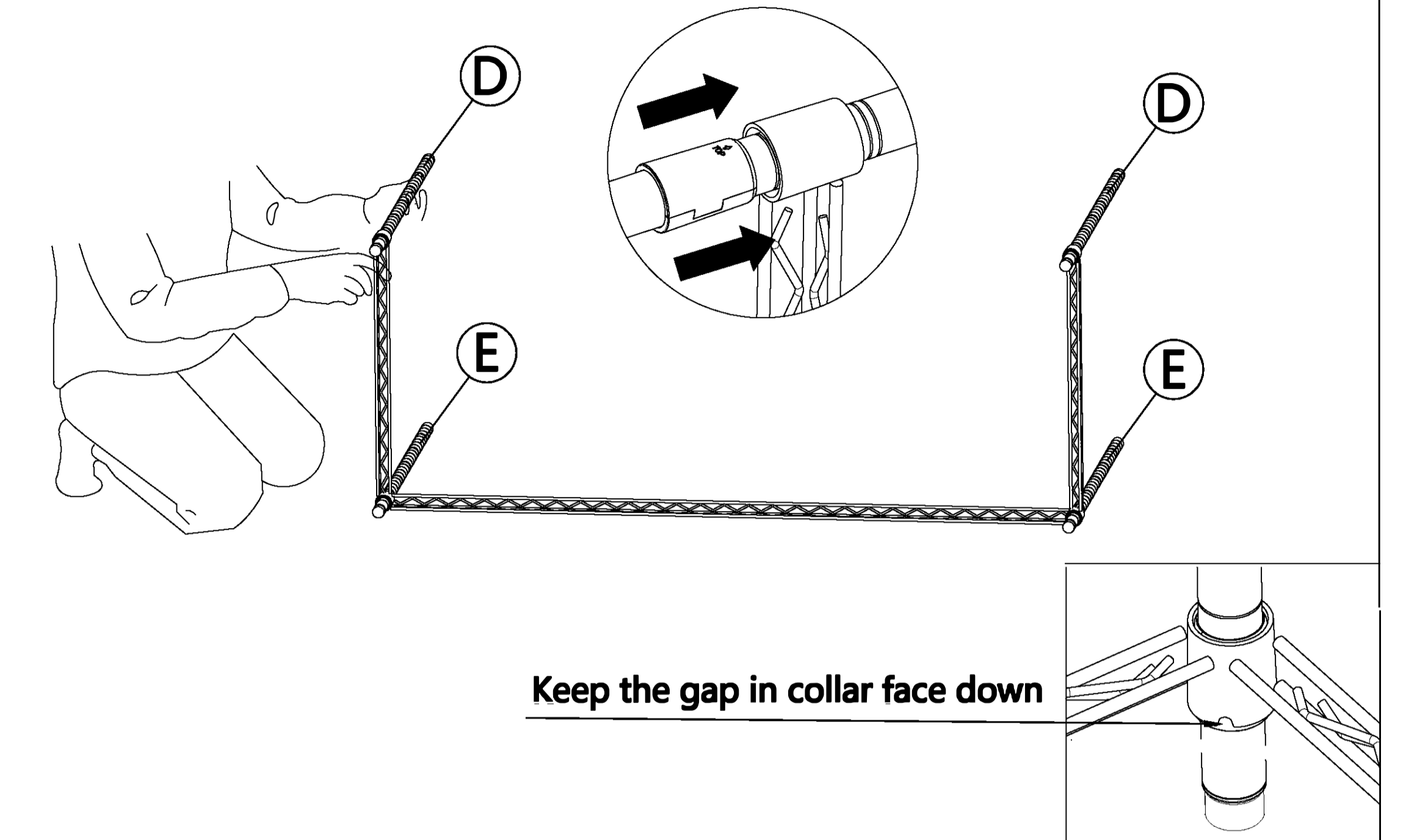

③ Set the wire shelf upright.Repeat step ①, ② to snap the plastic clips on the same groove of each pole at your next desired position and assemble wire shelf(A).

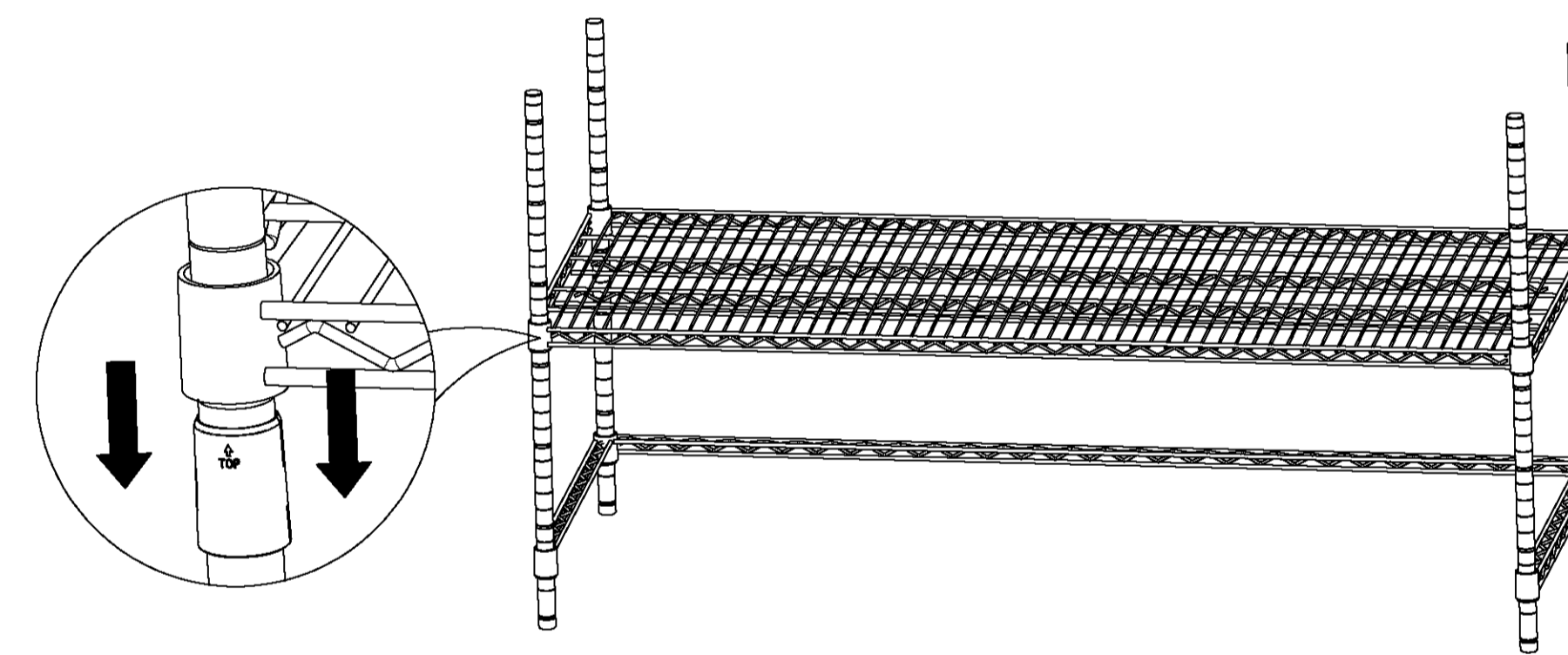

④ Screw Upper Poles (F) into lower poles(E) by connectors which are already assembled on the upper poles.

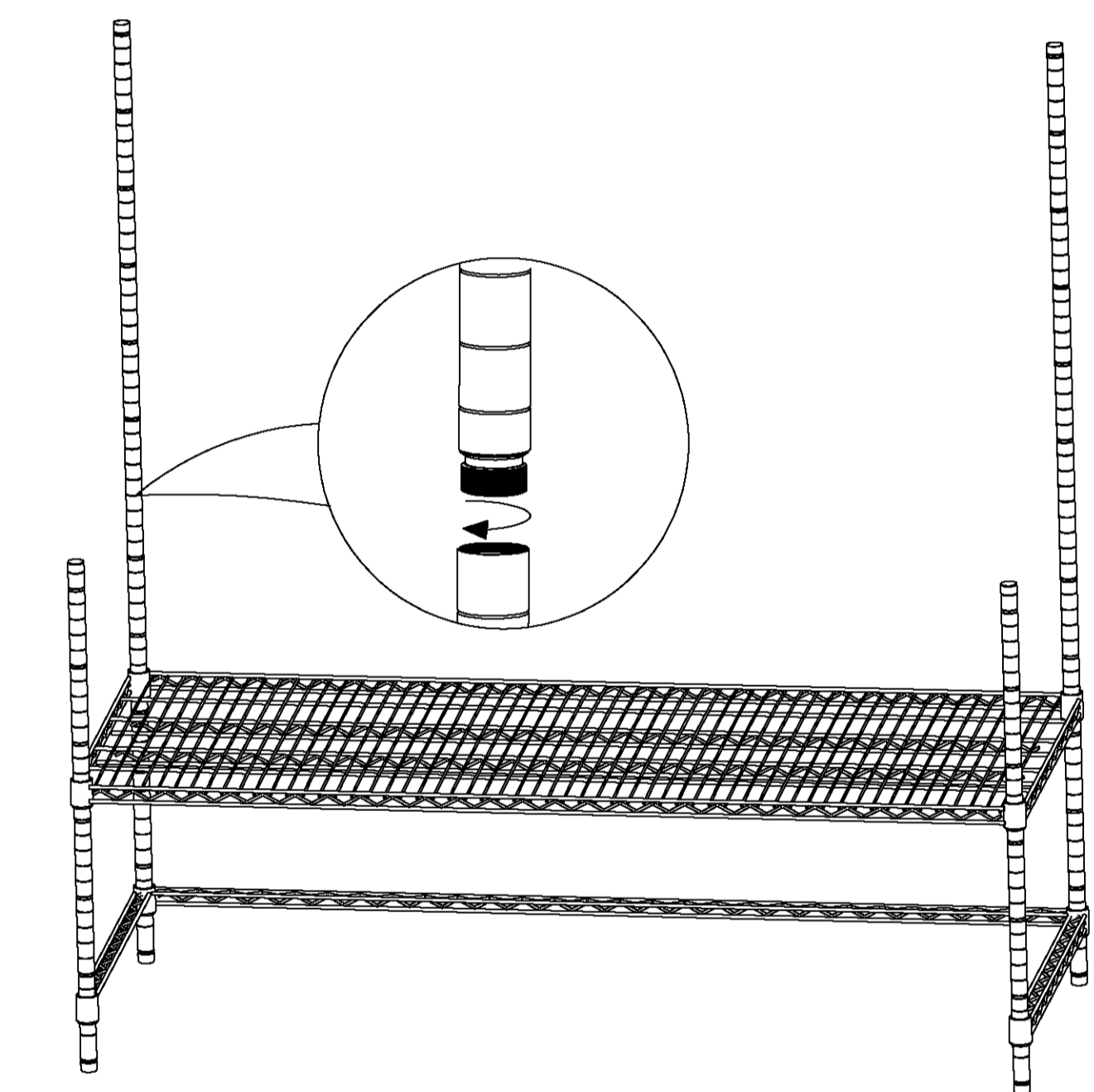

⑤ Snap plastic clips(H) into the top of front pole and lower pole of the same height. Then Slide down the second shelf from top down onto the plastic clips.Snap plastic clips(H) into the top of upper pole and slide down the semi-round wire shelf onto the plastic clips.

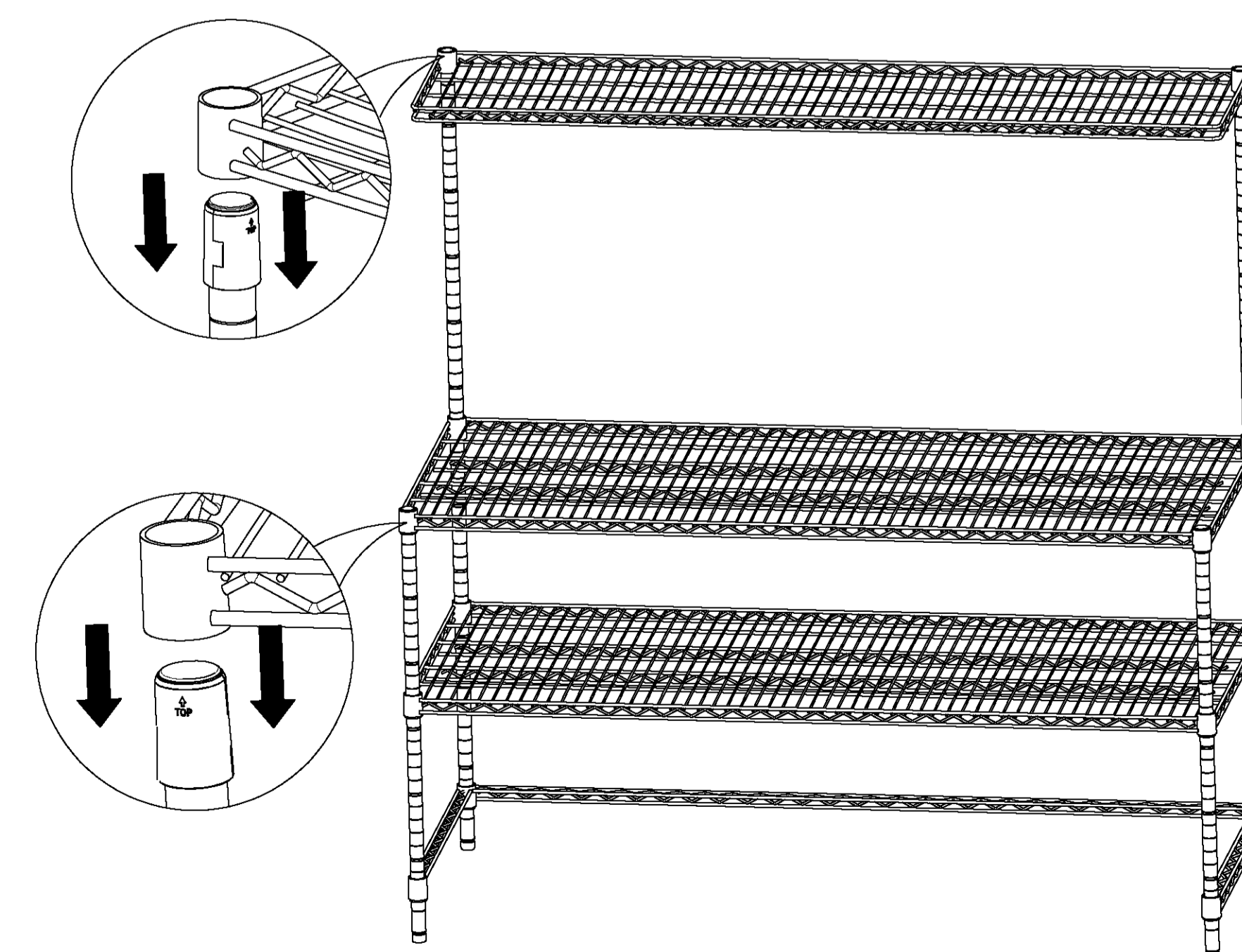

⑥ Once all the wire shelves have been installed, pushing firmly down on every shelf at corners by rubber mallet to ensure that the shelf is in a place over the plastic clips.Put the PP mat(G) on the second wire shelf,then you finish the Installation.

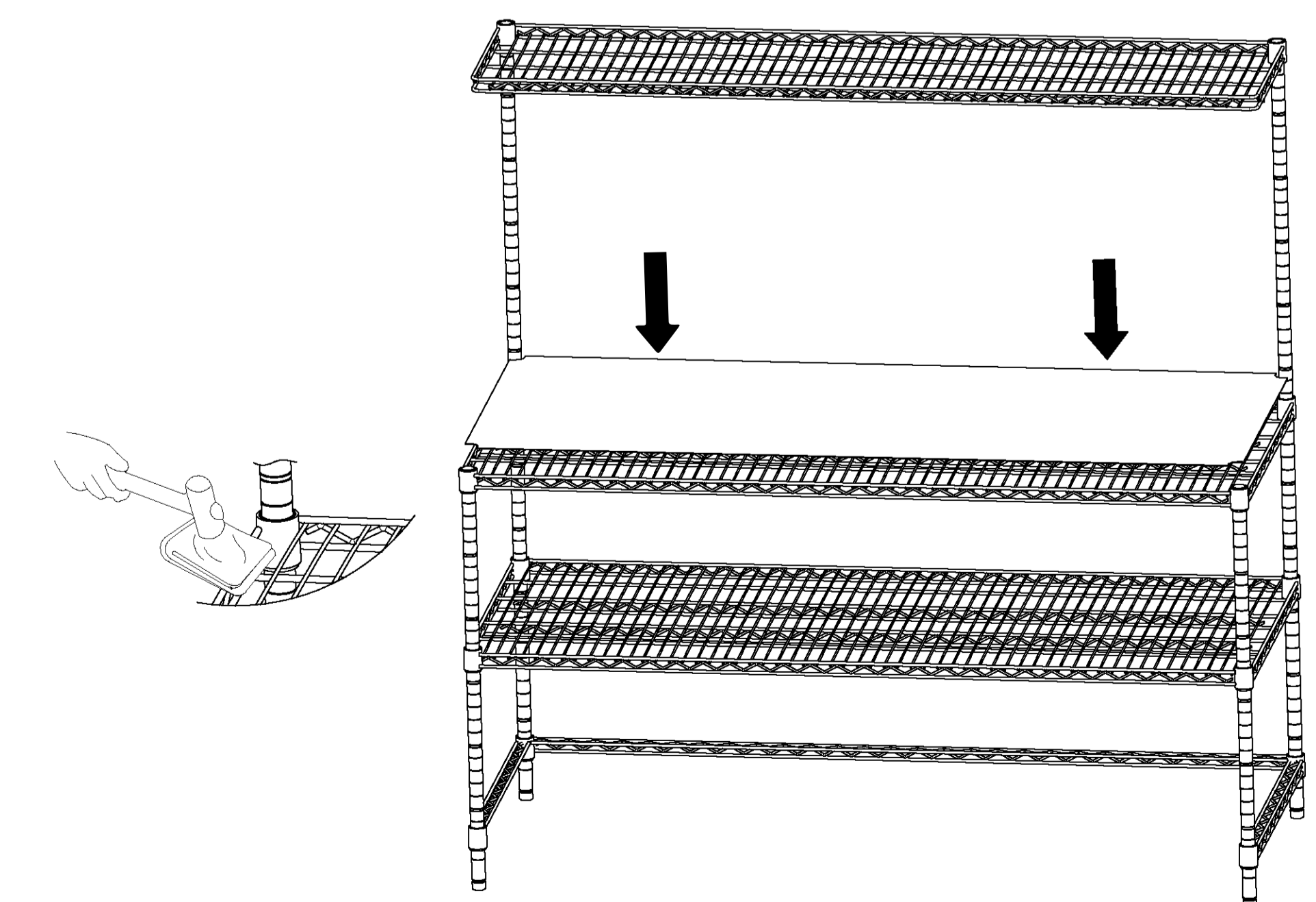

No.	A	B	C	D	E	F	G	H	I
Name	Wire Shelf	Semi-round Wire Shelf	Shelf Frame	Front Pole	Lower Pole	Upper Pole	PP Mat	Plastic Clip	Leveling Feet
Parts									
Quantity	2PCS	1PC	1PC	2PCS	2PCS	2PCS	1PC	28PCS	4PCS